

# HRT Series

Large Aperture Hollow Rotary Table  
大孔径中空旋转平台



## 订货型号表示

### Ordering Representation

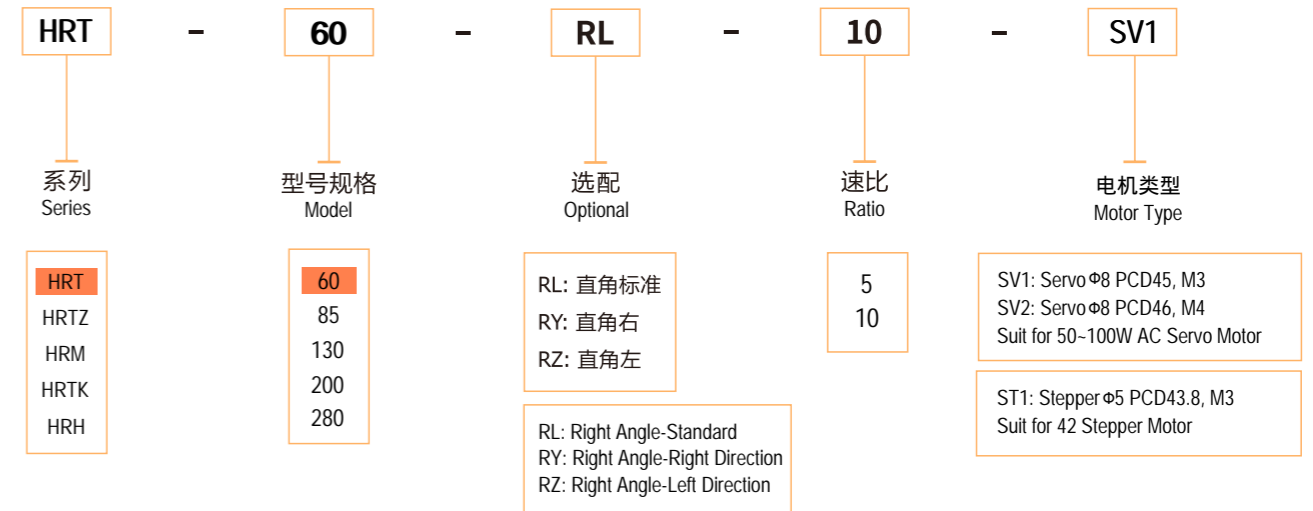

## 技术参数

### Technical Parameter

型号 Model		HRT60		HRT60RL/RZ		
轴承结构 Bearing structure		交叉滚子轴承 Cross roller bearing				
减速比 Reduction ratio	I	5	10	10	15	25
额定输出扭矩 Rated output torque	N.m	9	6	9	9	9
最大输出扭矩 Output torque	N.m	3倍额定扭矩 3 Times rated torque				
定位精度 Positioning accuracy	arc-min	$\leq 1.5$		$\leq 3$		
反复定位精度 Repeated positioning accuracy	arc-sec	$\leq 15$		$\leq 30$		
容许盘面转速 Allowable disk speed	rpm	200 (间歇运转) Intermittent operation				
适配伺服马达 Adapt to servo motor	W	50-100				
适配步进马达 Suitable for stepping motor		42 步进 Stepper				
容许轴向负载 Allowable axial load	N	230				
容许惯性力矩 Allowable moment of inertia	N.m	5				
扭转刚性 Torsional rigidity	N.m/arcmin	2.5				
齿隙 Backlash		无齿隙 (可调节结构) No backlash (Adjustable structure)				
精度寿命 Accuracy life	h	30000h (间歇运转) Intermittent operation				
防护等级 Protection level	IP	50				
润滑方式 Lubrication method		长效润滑 Long-term lubrication				
安装方式 Installation method		任意 Arbitrary				
旋转平台同心度 Concentricity of rotating platform	mm	$\leq 0.01$				
旋转平台平行度 Parallelism of rotating platform	mm	$\leq 0.01$				
传动效率 Transmission efficiency	%	95		90		
噪音 Noise	db	$\leq 55$		$\leq 57$		
重量 Weight	kg	0.6		1.2		
设计承重 Design load	kg	7	5	7		

\* 以上技术参数仅供参考，实际根据客户提供的数据，会出具相关的技术参数及尺寸。

The above data is for reference only. Based on the data provided by the customer, relevant technical parameters and dimensions will be provided.

外形尺寸图表  
Outline dimensional

HRT60-5 配42步进接口 for 42 Stepper Interface

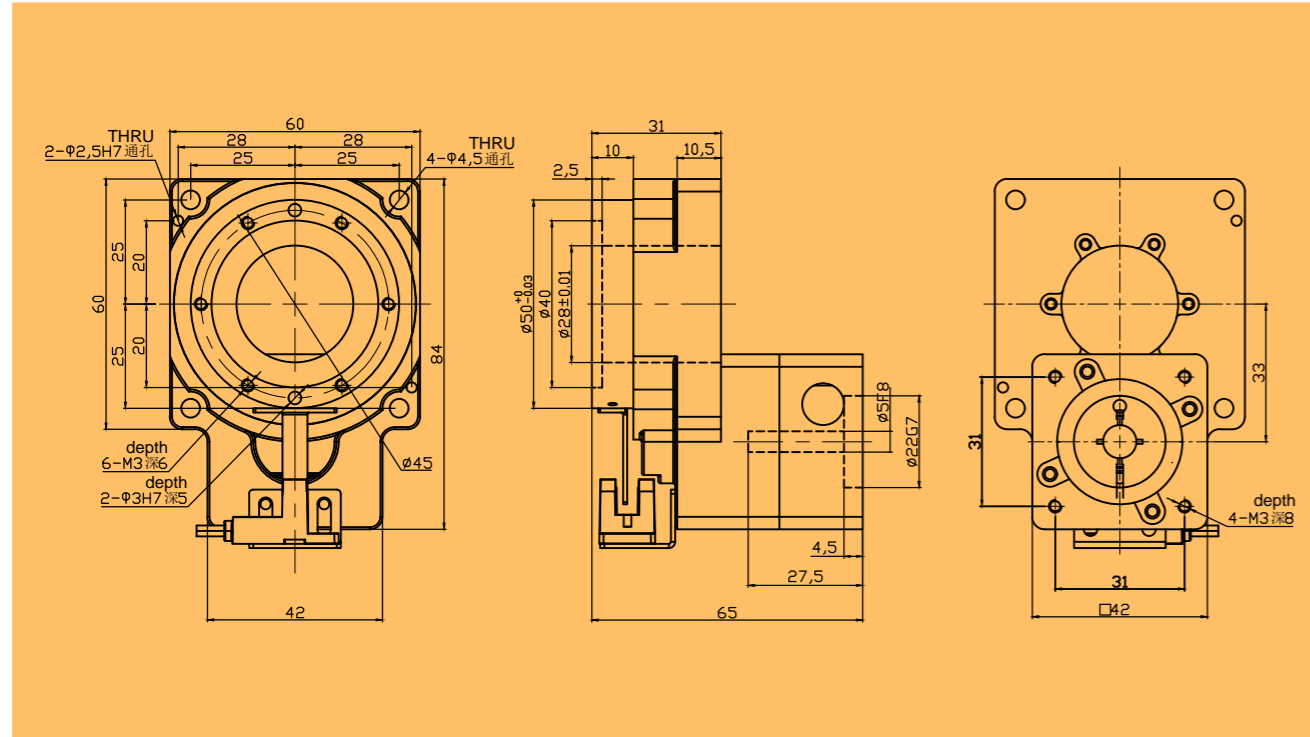

外形尺寸图表  
Outline dimensional

HRT60-10 配42步进接口 for 42 Stepper Interface

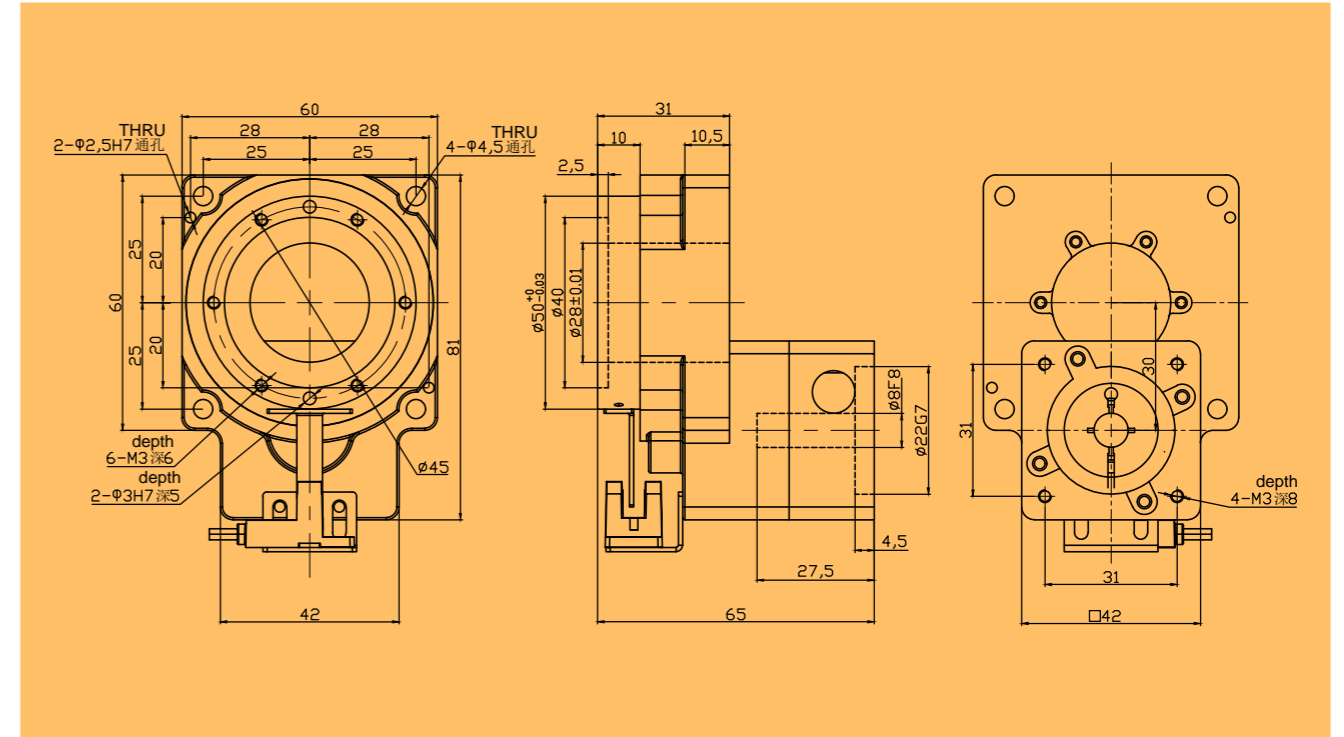

HRT60-5 配100W伺服接口 for 100W Servo Interface

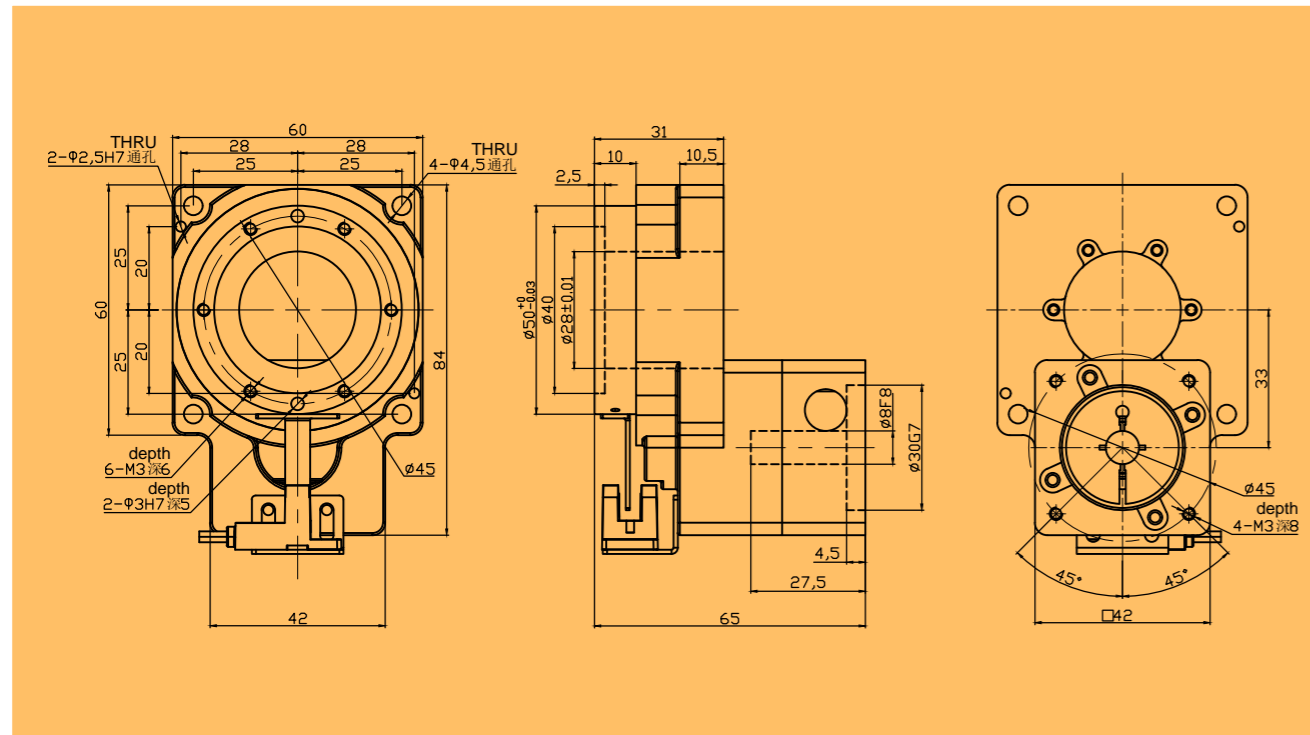

HRT60-10 配100W伺服接口 for 100W Servo Interface

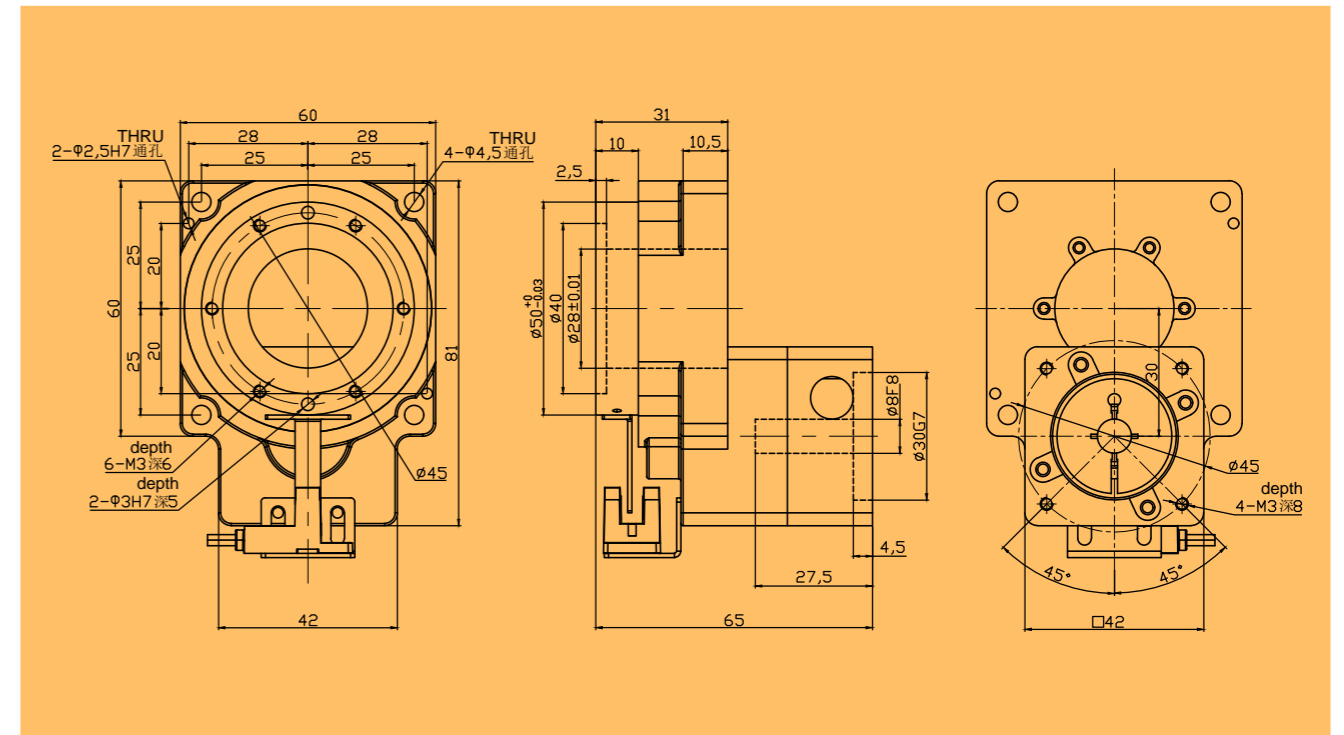

\* 以上技术参数仅供参考，实际根据客户提供的数据，会出具相关的技术参数及尺寸。  
The above data is for reference only. Based on the data provided by the customer, relevant technical parameters and dimensions will be provided

\* 以上技术参数仅供参考，实际根据客户提供的数据，会出具相关的技术参数及尺寸。  
The above data is for reference only. Based on the data provided by the customer, relevant technical parameters and dimensions will be provided



订货型号表示  
Ordering Representation

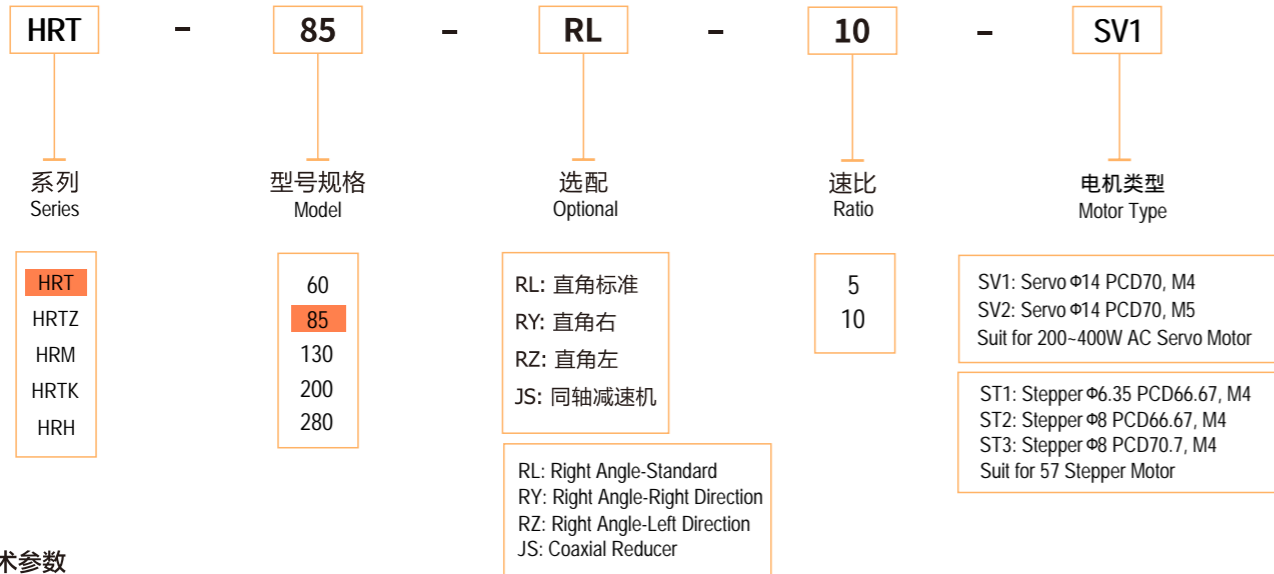

技术参数  
Technical Parameter

型号 Model		HRT85	HRT85RL/RY/RZ(JS)						
轴承结构 Bearing structure		交叉滚子轴承 Cross roller bearing							
减速比 Reduction ratio	I	5	10	15	20	25	35	50	
额定输出扭矩 Rated output torque	N.m	28	18	28	28	28	28	28	
最大输出扭矩 Output torque	N.m	3倍额定扭矩 3 Times rated torque							
定位精度 Positioning accuracy	arc-min	$\leq 1$			$\leq 3$				
反复定位精度 Repeated positioning accuracy	arc-sec	$\leq 15$			$\leq 30$				
容许盘面转速 Allowable disk speed	rpm	200 (间歇运转) Intermittent operation							
适配伺服马达 Adapt to servo motor	W	200-400							
适配步进马达 Suitable for stepping motor		57 步进 Stepper							
容许轴向负载 Allowable axial load	N	500							
容许惯性力矩 Allowable moment of inertia	N.m	10							
扭转刚性 Torsional rigidity	N.m/arcmin	6							
齿隙 Backlash		无齿隙 (可调节结构) No backlash (Adjustable structure)							
精度寿命 Accuracy life	h	30000h (间歇运转) Intermittent operation							
防护等级 Protection level	IP	50							
润滑方式 Lubrication method		长效润滑 Long-term lubrication							
安装方式 Installation method		任意 Arbitrary							
旋转平台同心度 Concentricity of rotating platform	mm	$\leq 0.01$							
旋转平台平行度 Parallelism of rotating platform	mm	$\leq 0.01$							
传动效率 Transmission efficiency	%	95			90				
噪音 Noise	db	$\leq 55$			$\leq 60$				
重量 Weight	kg	1.4			2.6				
设计承重 Design load	kg	18			28				

注 HRT85JS系列速比有15/20/25/35/50等。额定输出扭矩40N.m。  
The speed ratio of HRT85JS series is 15/20/25/35/50 etc. The rated output torque is 40N.m.

外形尺寸图表  
Outline dimensional

HRT85-5 配400W伺服接口 for 400W Servo Interface

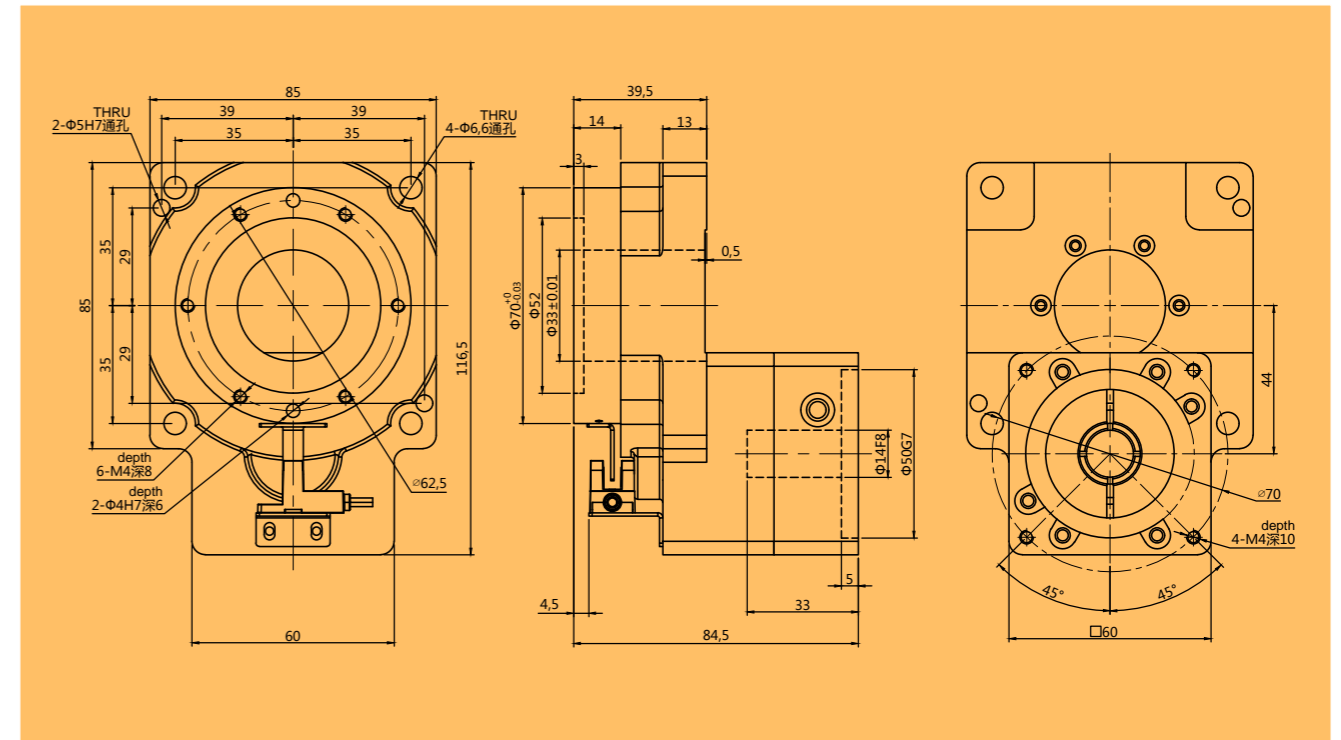

HRT85-5 配57步进接口 for 57 Stepper Interface

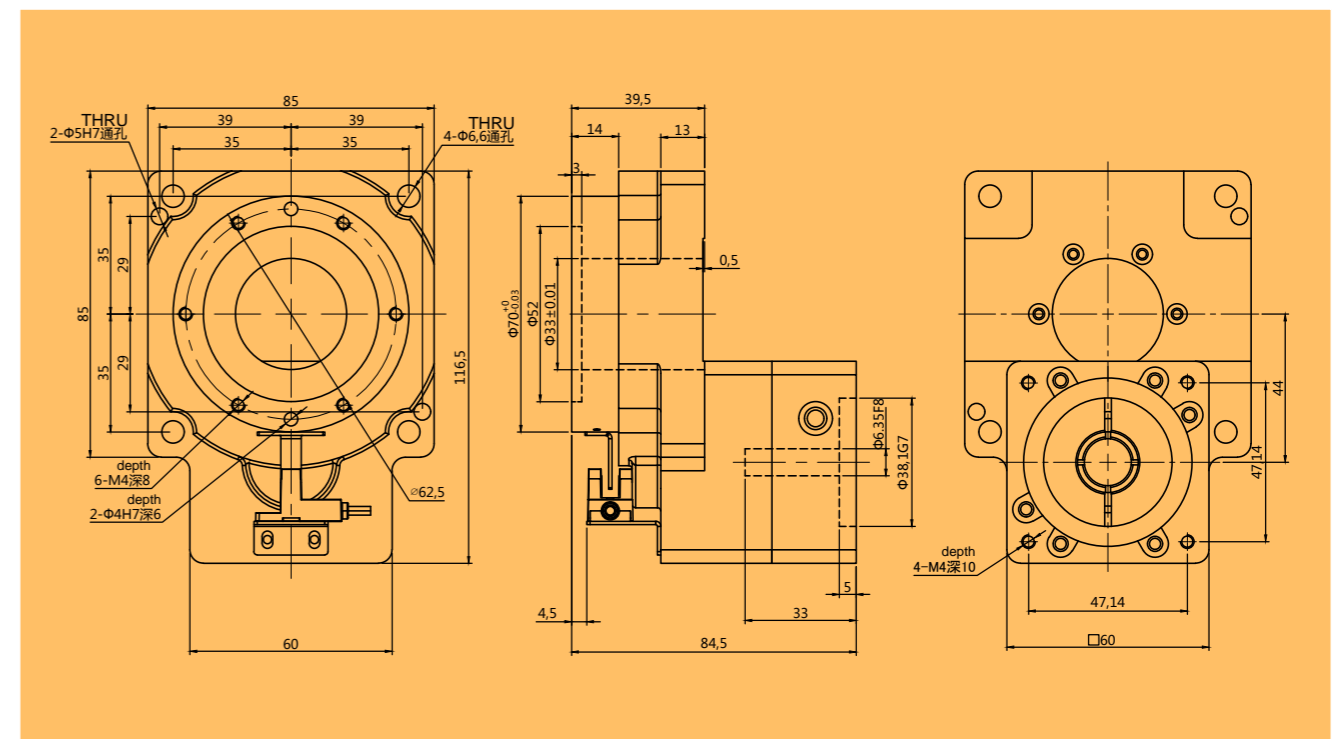

\* 以上技术参数仅供参考，实际根据客户提供的数据，会出具相关的技术参数及尺寸。  
The above data is for reference only. Based on the data provided by the customer, relevant technical parameters and dimensions will be provided



外形尺寸图表  
Outline dimensional

HRT85-10 配400W伺服接口 for 400W Servo Interface

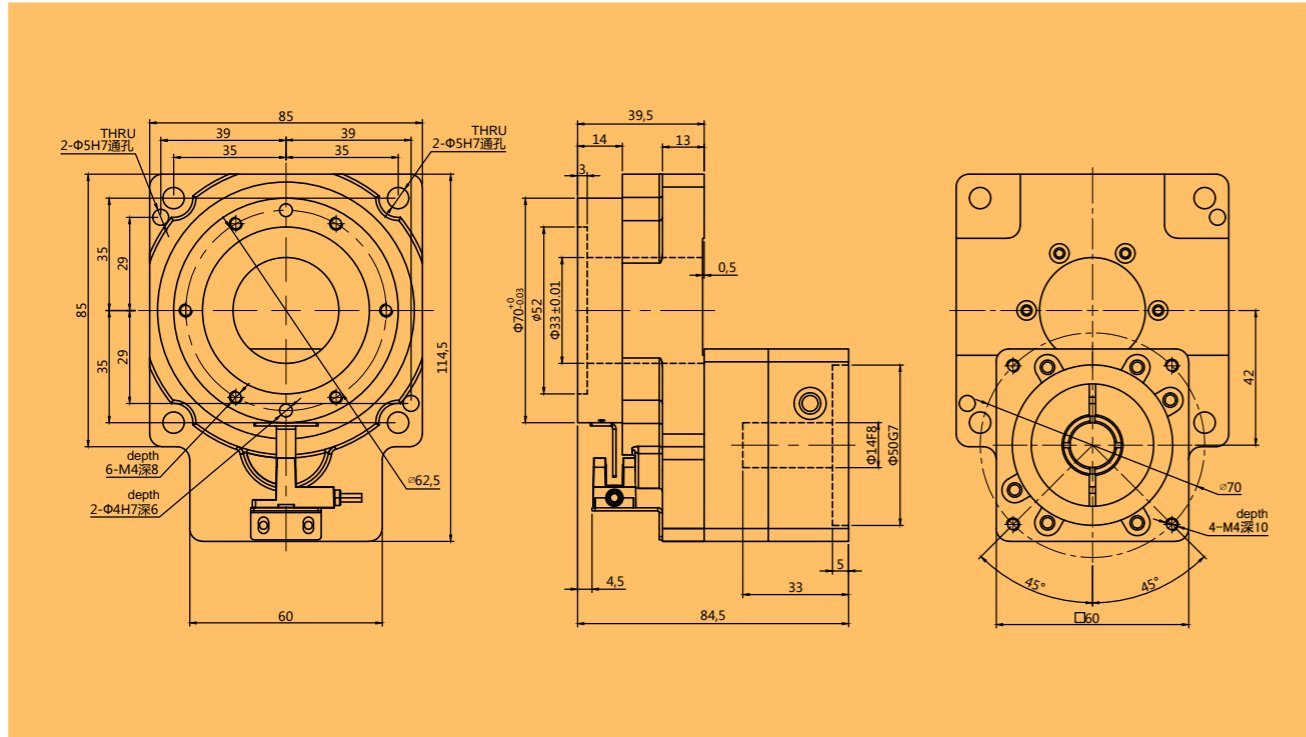

HRT85-10 配57步接口 for 57 Stepper Interface

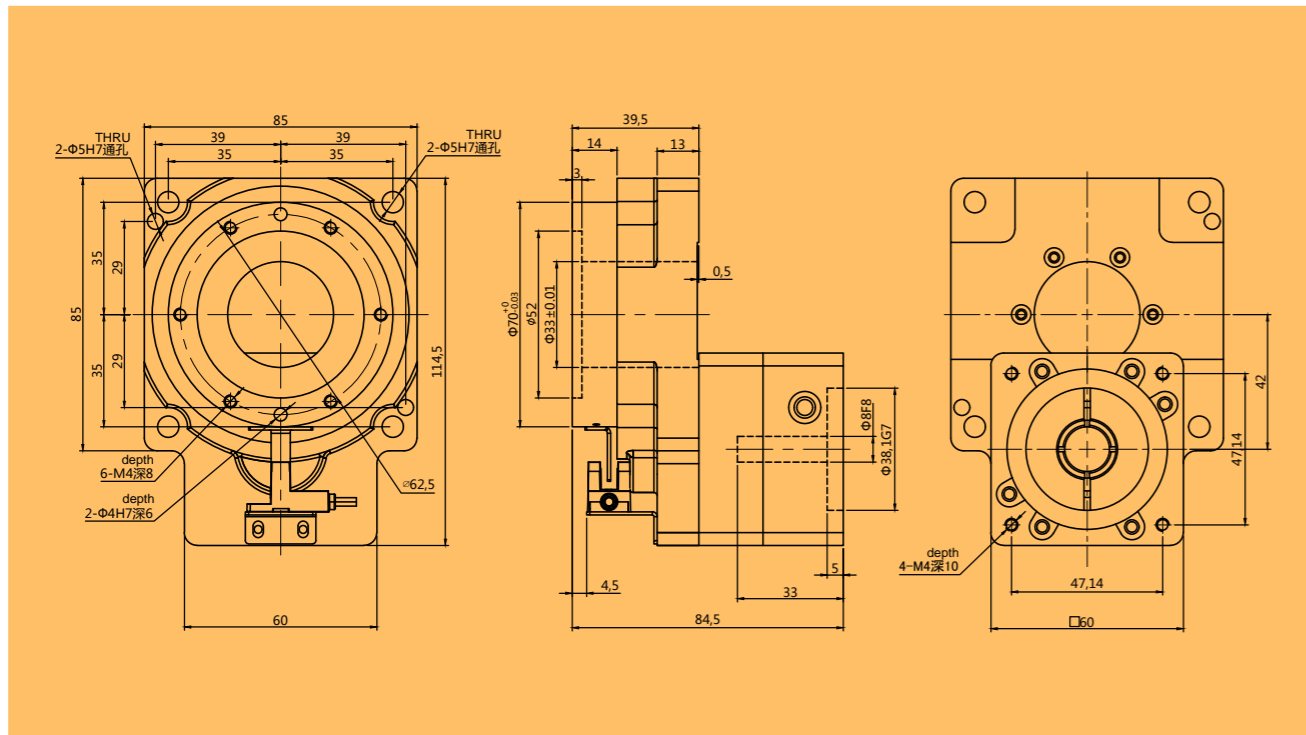

\* 以上技术参数仅供参考, 实际根据客户提供的数据, 会出具相关的技术参数及尺寸。  
The above data is for reference only. Based on the data provided by the customer, relevant technical parameters and dimensions will be provided

外形尺寸图表  
Outline dimensional

HRT85RL-10 配400W伺服接口 for 400W Servo Interface

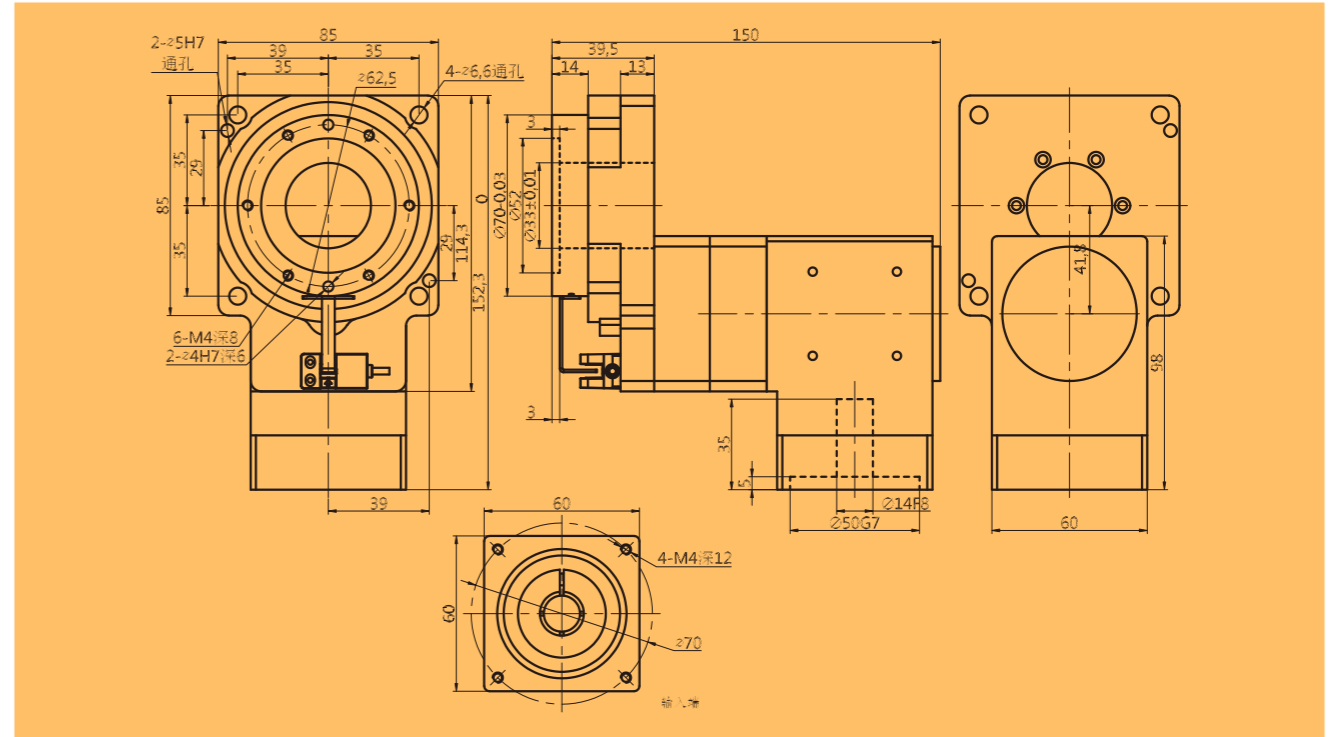

HRT85RY-10 配400W伺服接口 for 400W Servo Interface

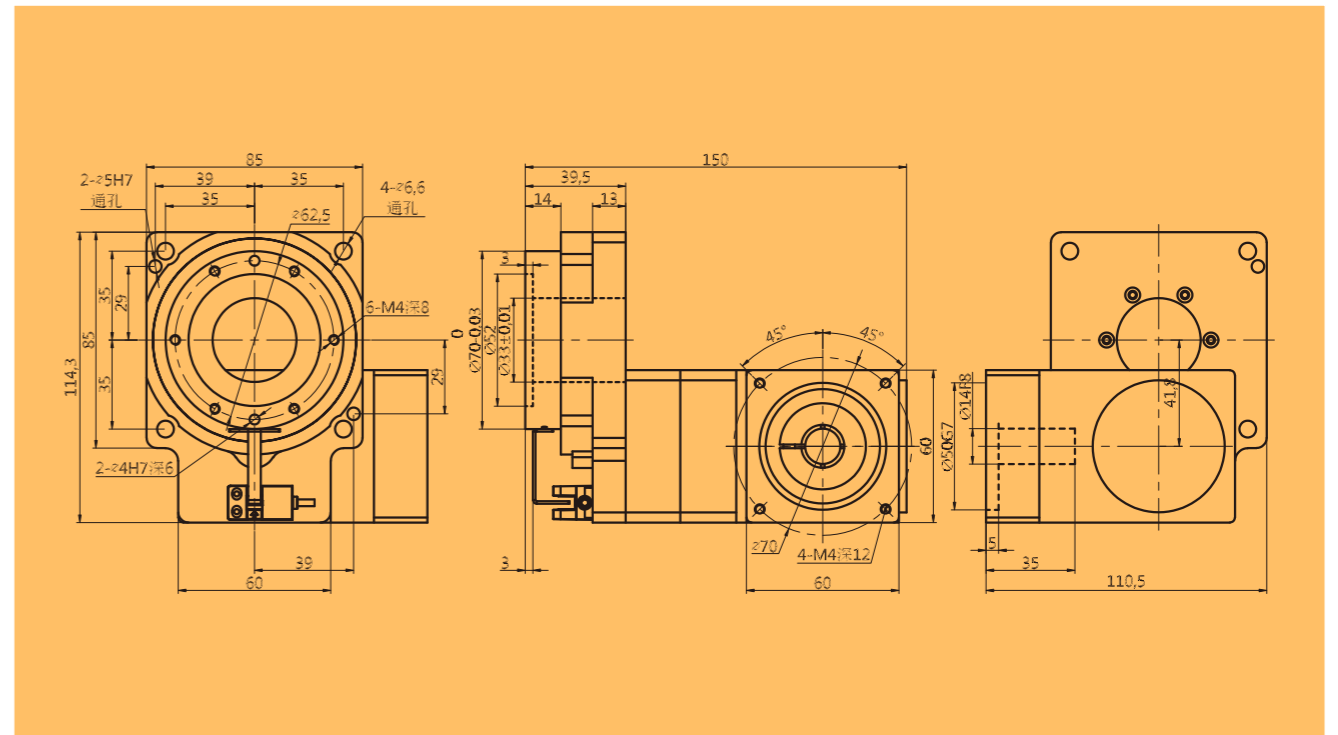

\* 以上技术参数仅供参考, 实际根据客户提供的数据, 会出具相关的技术参数及尺寸。  
The above data is for reference only. Based on the data provided by the customer, relevant technical parameters and dimensions will be provided

外形尺寸图表  
Outline dimensional

HRT85RZ-10 配400W伺服接口 for 400W Servo Interface

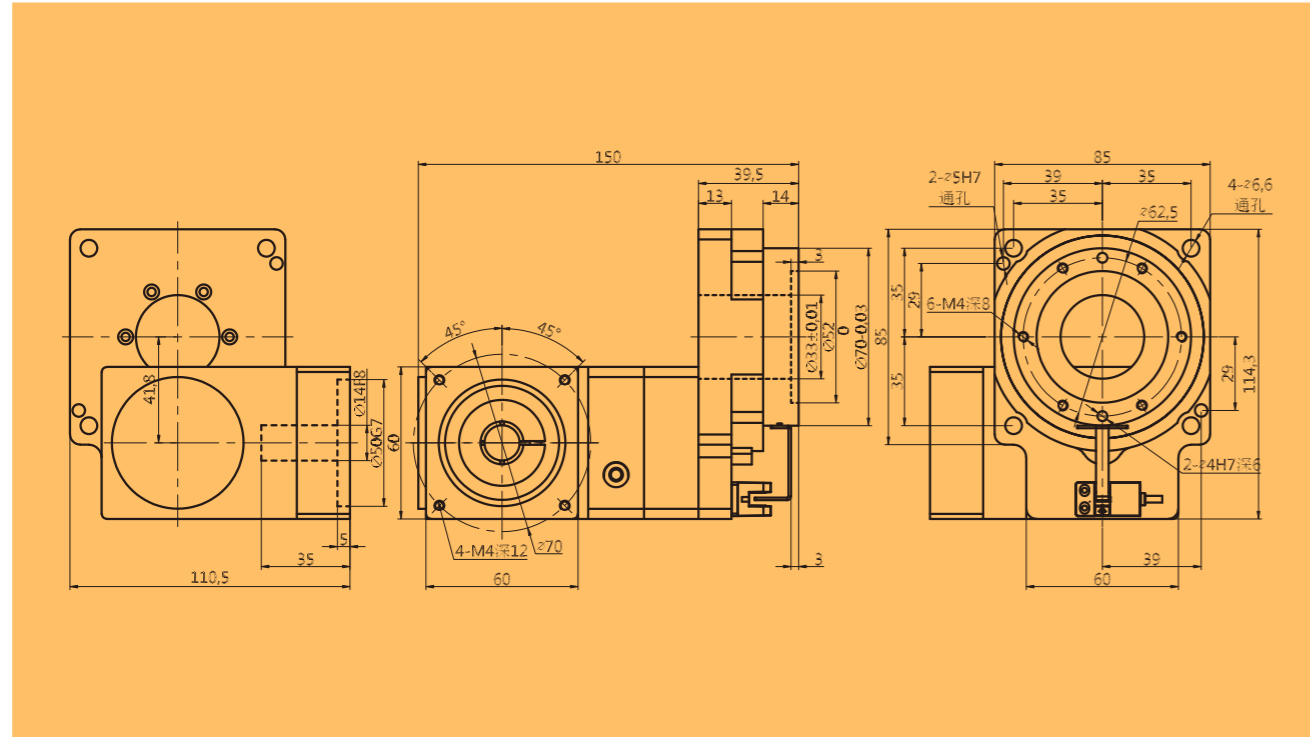

\* 以上技术参数仅供参考, 实际根据客户提供的数据, 会出具相关的技术参数及尺寸。  
The above data is for reference only. Based on the data provided by the customer, relevant technical parameters and dimensions will be provided



订货型号表示  
Ordering Representation

<b>HRT</b>	-	<b>130</b>	-	<b>RL</b>	-	<b>10</b>	-	<b>SV1</b>
系列 Series		型号规格 Model		选配 Optional		速比 Ratio		电机类型 Motor Type
HRT HRTZ HRM HRTK HRH		60 85 <b>130</b> 200 280		RL: 直角标准 RY: 直角右 RZ: 直角左 JS: 同轴减速机		10 18		SV1: Servo $\phi 14$ PCD70, M4 SV2: Servo $\phi 14$ PCD70, M5 Suit for 200-750W AC Servo Motor  ST1: Stepper $\phi 6.35$ PCD66.67, M4 ST2: Stepper $\phi 8$ PCD66.67, M4 ST3: Stepper $\phi 8$ PCD70.7, M4 ST4: Stepper $\phi 14$ PCD98.4, M5 Suit for 57-86 Stepper Motor
				RL: Right Angle-Standard RY: Right Angle-Right Direction RZ: Right Angle-Left Direction JS: Coaxial Reducer				

技术参数  
Technical Parameter

型号 Model		HRT130	HRT130RL/RZ/RZ(JS)						
轴承结构 Bearing structure			交叉滚子轴承 Cross roller bearing						
减速比 Reduction ratio	I	10	18	30	40	50	70	100	
额定输出扭矩 Rated output torque	N.m	50	32	50	50	50	50	50	
最大输出扭矩 Output torque	N.m	3倍额定扭矩 3 Times rated torque							
定位精度 Positioning accuracy	arc-min	≤1			≤3				
反复定位精度 Repeated positioning accuracy	arc-sec	≤15			≤30				
容许盘面转速 Allowable disk speed	rpm	200 (间歇运转) Intermittent operation							
适配伺服马达 Adapt to servo motor	W	200-750							
适配步进马达 Suitable for stepping motor		57-86 步进 Stepper							
容许轴向负载 Allowable axial load	N	2000							
容许惯性力矩 Allowable moment of inertia	N.m	50							
扭转刚性 Torsional rigidity	N.m/arcmin	19							
齿隙 Backlash		无齿隙 (可调节结构) No backlash (Adjustable structure)							
精度寿命 Accuracy life	h	30000h (间歇运转) Intermittent operation							
防护等级 Protection level	IP	50							
润滑方式 Lubrication method		长效润滑 Long-term lubrication							
安装方式 Installation method		任意 Arbitrary							
旋转平台同心度 Concentricity of rotating platform	mm	≤0.01							
旋转平台平行度 Parallelism of rotating platform	mm	≤0.013							
传动效率 Transmission efficiency	%	95					90		
噪音 Noise	db	≤60					≤60		
重量 Weight	kg	2.6					3.8		
设计承重 Design load	kg	28-40					40		

注 ① HRT130JS系列速比有30/40/50/70/100等。额定输出扭矩65N.m。 ② 旋转平台平行度有更高要求请联系我司销售人员  
① HRT130JS series speed ratio has 30/40/50/70/100 etc. The rated output torque is 65N.m. ② If the parallelism of the rotating platform has higher requirements, please contact our sales staff

外形尺寸图表  
Outline dimensional

HRT130-10 配400W伺服接口 for 400W Servo Interface

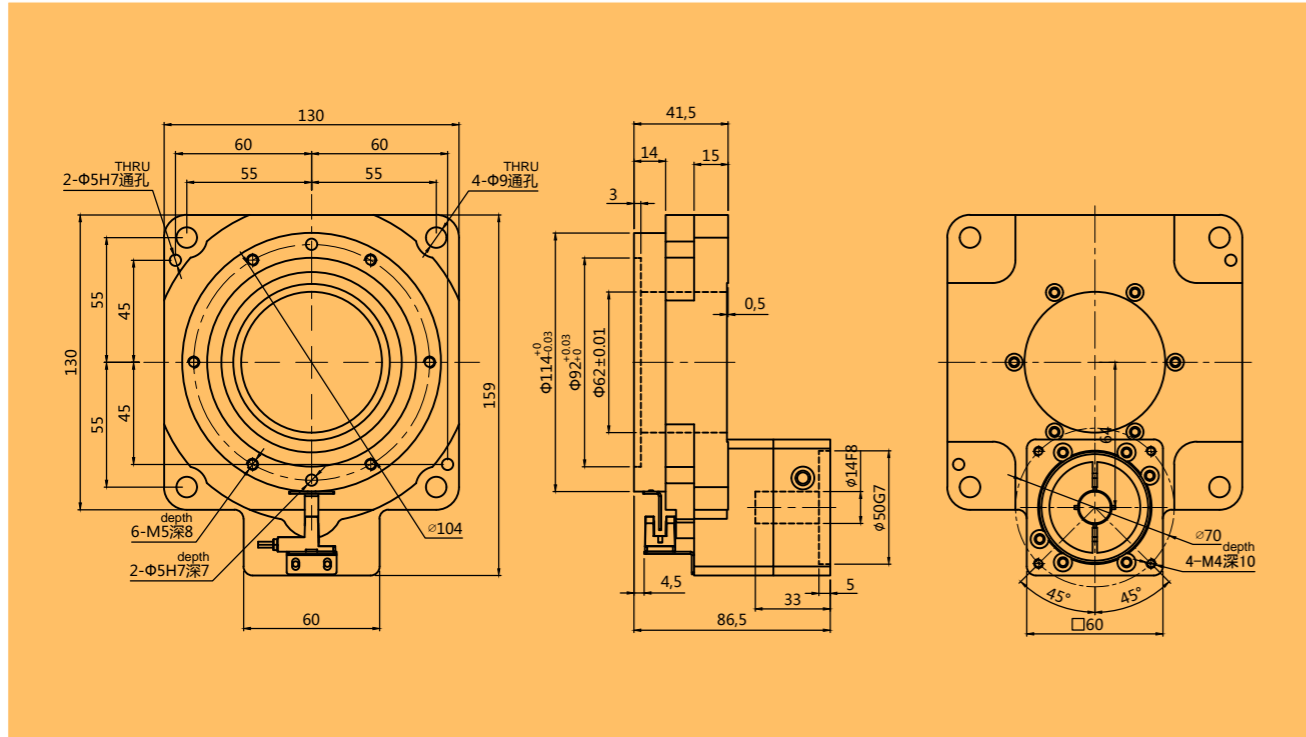

外形尺寸图表  
Outline dimensional

HRT130-10 配86步接口 for 86 Stepper Interface

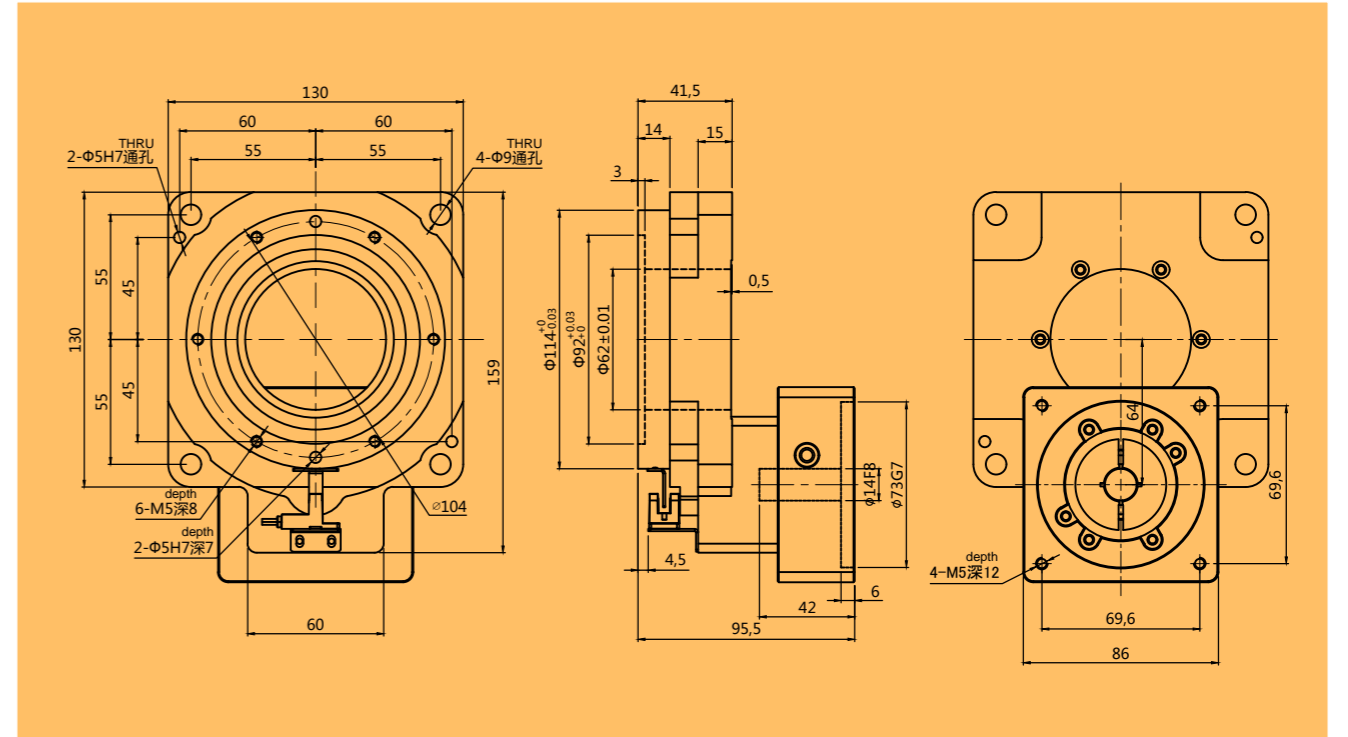

HRT130-10 配57步接口 for 57 Stepper Interface

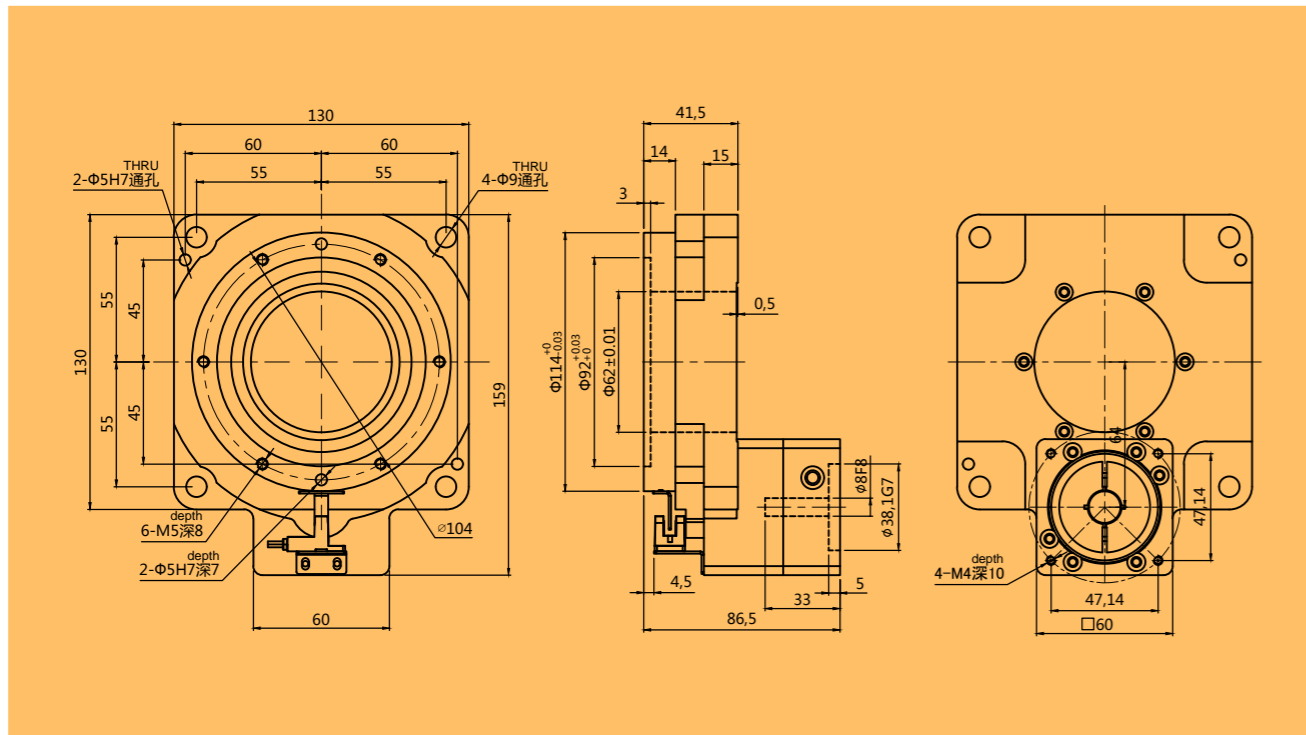

HRT130JS-10 配400W伺服接口 for 400W Servo Interface

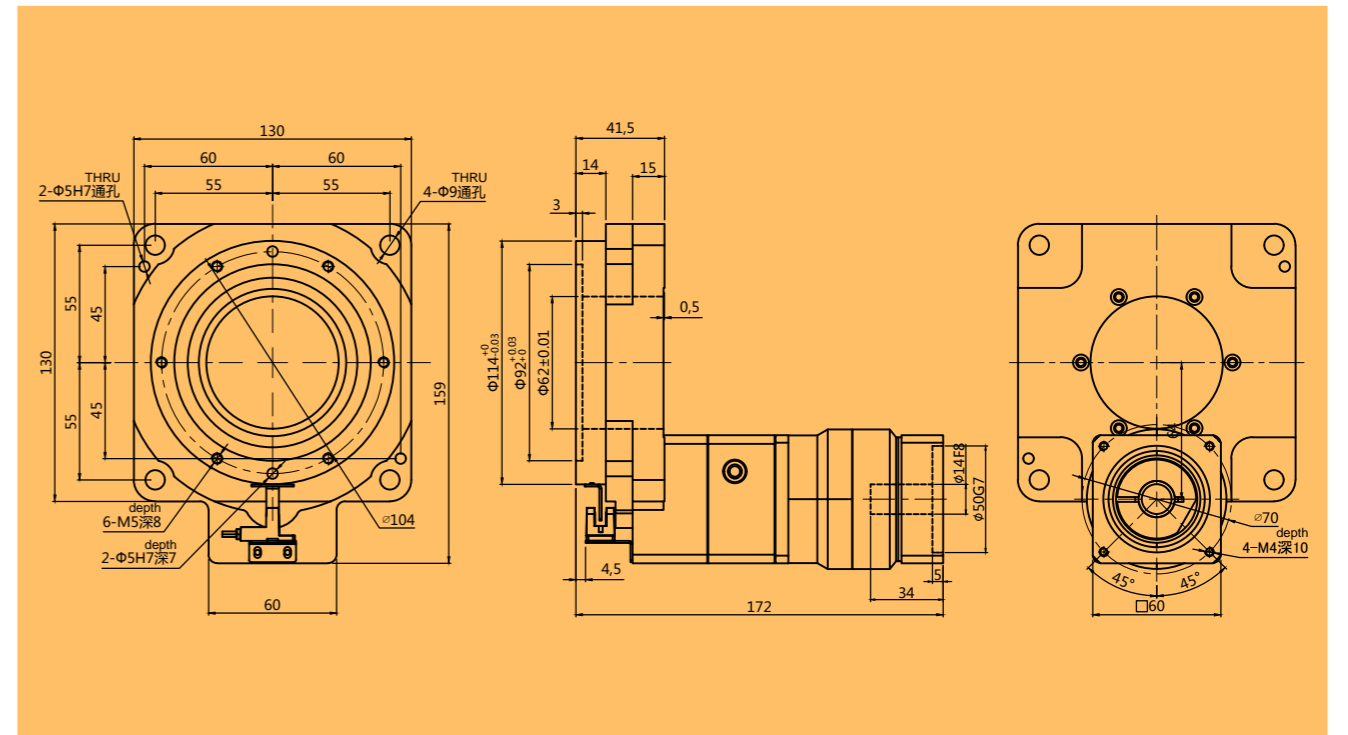

\* 以上技术参数仅供参考, 实际根据客户提供的数据, 会出具相关的技术参数及尺寸。  
The above data is for reference only. Based on the data provided by the customer, relevant technical parameters and dimensions will be provided

\* 以上技术参数仅供参考, 实际根据客户提供的数据, 会出具相关的技术参数及尺寸。  
The above data is for reference only. Based on the data provided by the customer, relevant technical parameters and dimensions will be provided

外形尺寸图表  
Outline dimensional

HRT130RL-10 配400W伺服接口 for 400W Servo Interface

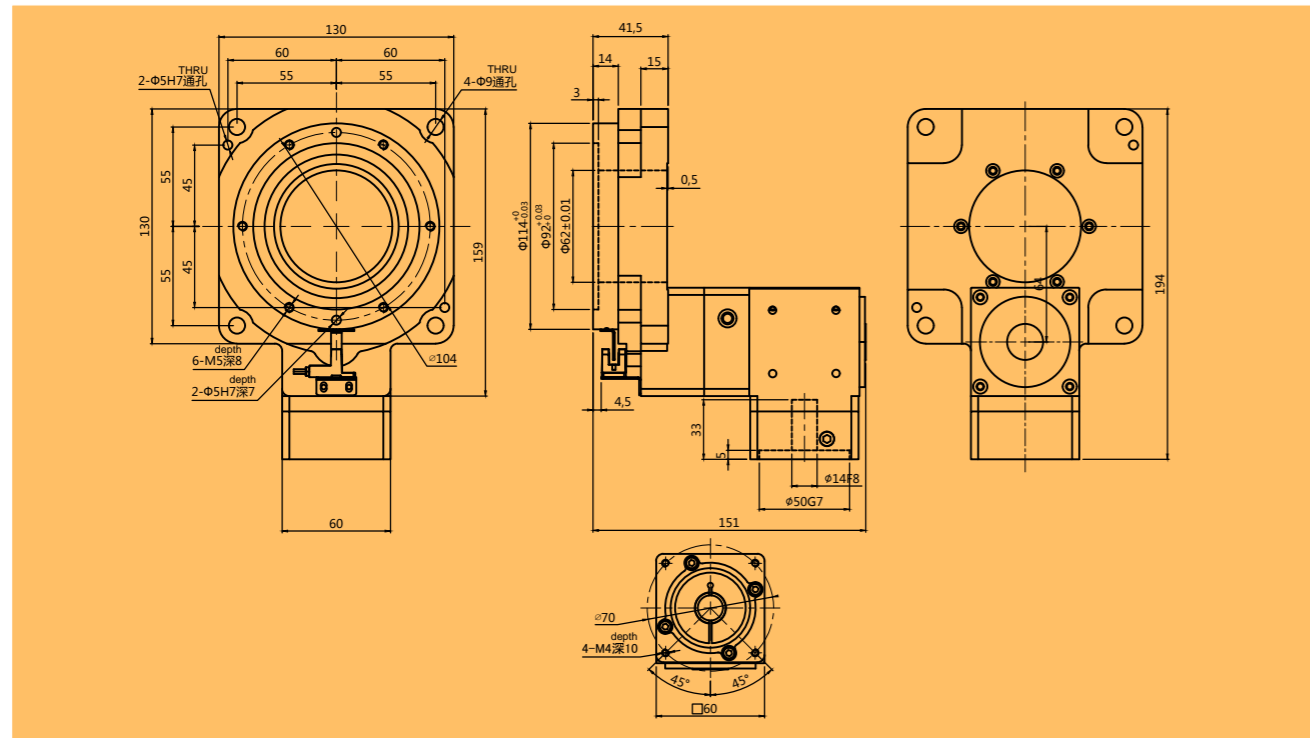

外形尺寸图表  
Outline dimensional

HRT130RZ-10 配400W伺服接口 for 400W Servo Interface

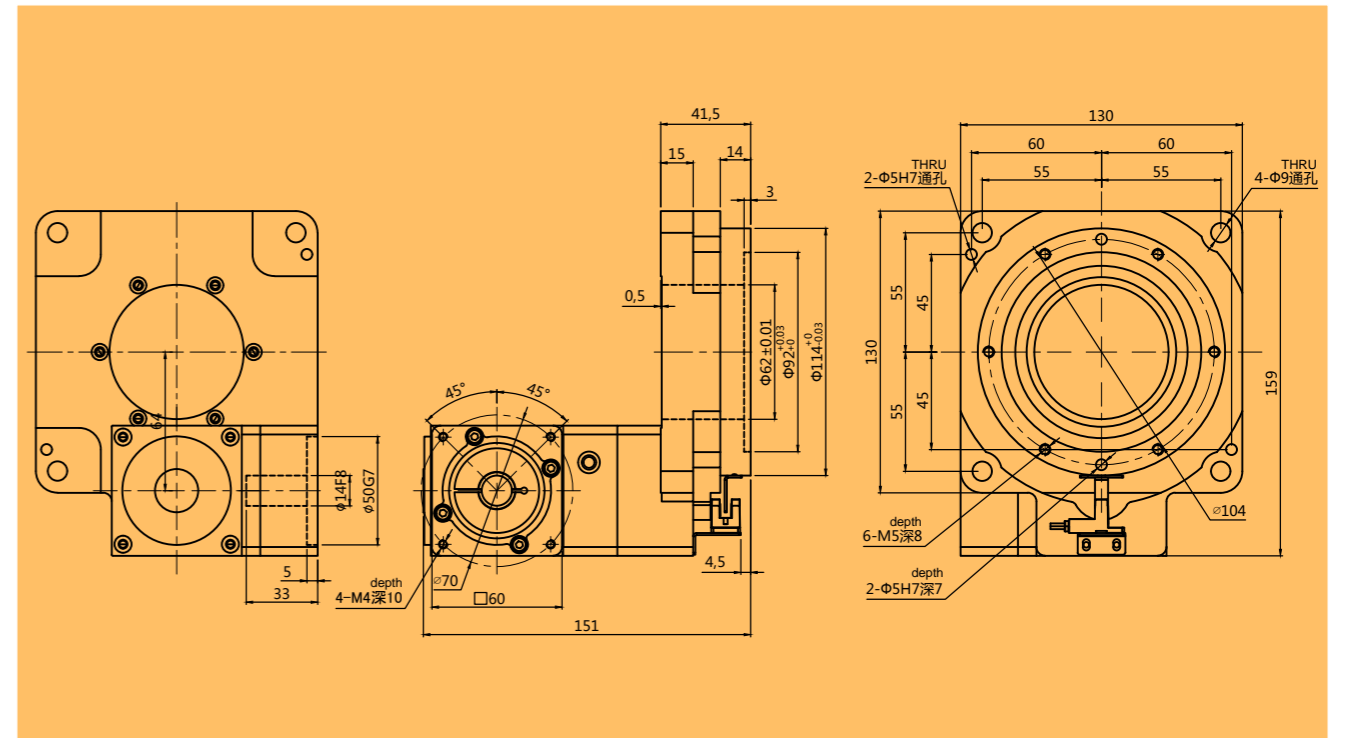

\* 以上技术参数仅供参考，实际根据客户提供的数据，会出具相关的技术参数及尺寸。  
The above data is for reference only. Based on the data provided by the customer, relevant technical parameters and dimensions will be provided

HRT130RY-10 配400W伺服接口 for 400W Servo Interface

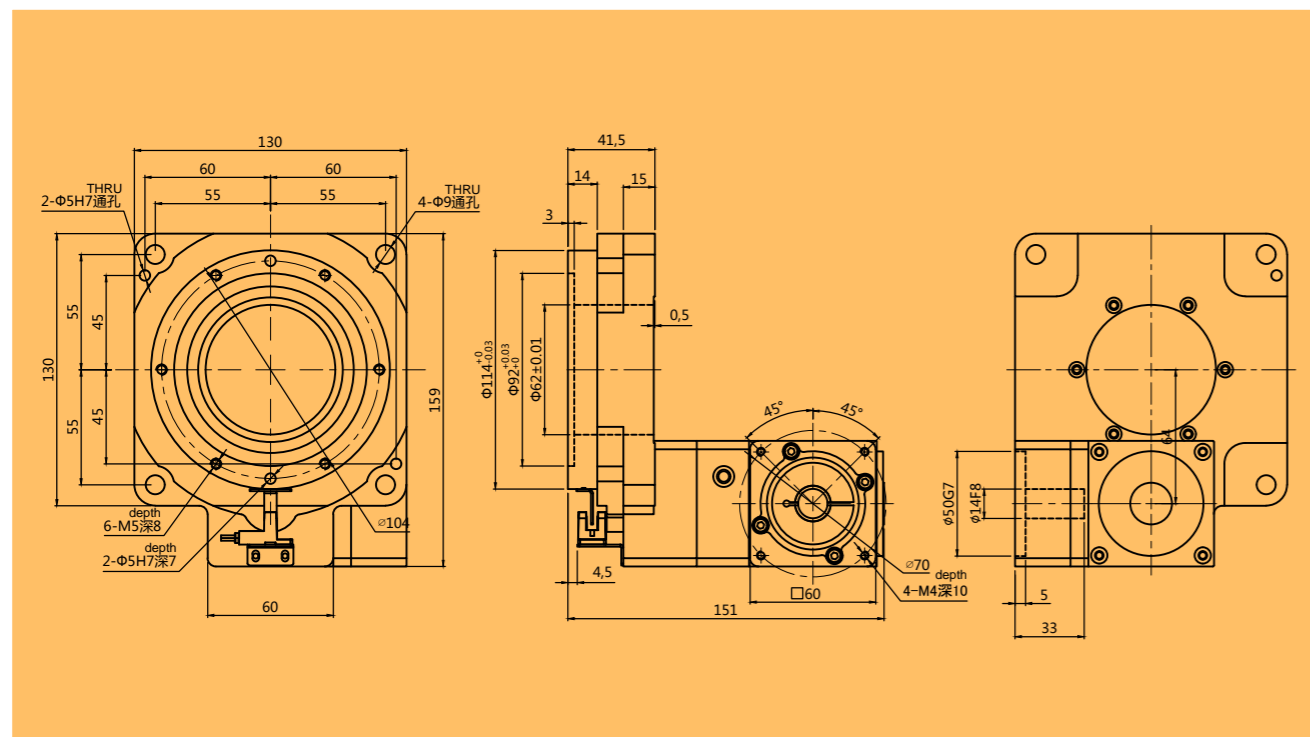

\* 以上技术参数仅供参考，实际根据客户提供的数据，会出具相关的技术参数及尺寸。  
The above data is for reference only. Based on the data provided by the customer, relevant technical parameters and dimensions will be provided

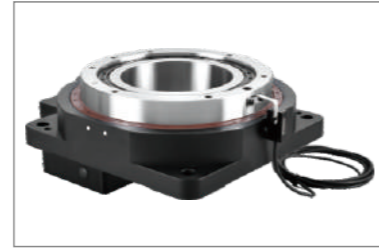

订货型号表示  
Ordering Representation

<b>HRT</b>	-	<b>200</b>	-	<b>RL</b>	-	<b>10</b>	-	<b>SV1</b>
系列 Series		型号规格 Model		选配 Optional		速比 Ratio		电机类型 Motor Type
HRT HRTZ HRM HRTK HRH		60 85 130 <b>200</b> 280		RL: 直角标准 RY: 直角右 RZ: 直角左 JS: 同轴减速机  RL: Right Angle-Standard RY: Right Angle-Right Direction RZ: Right Angle-Left Direction JS: Coaxial Reducer		10 18		SV1: Servo $\phi 19$ PCD90, M5 SV2: Servo $\phi 19$ PCD90, M6 SV3: Servo $\phi 22$ PCD145, M8 Suit for 750-1500W AC Servo Motor  ST1: Stepper $\phi 8$ PCD66.67, M4 ST2: Stepper $\phi 12.7$ PCD98.4, M5 ST3: Stepper $\phi 14$ PCD98.4, M5 (60) ST4: Stepper $\phi 14$ PCD98.4, M5 (73) ST5: Stepper $\phi 14$ PCD98.4, M6 (73) ST6: Stepper $\phi 19$ PCD100, M6 Suit for 86-110 Stepper Motor

技术参数  
Technical Parameter

型号 Model		HRT200	HRT200RL/RY/RZ(JS)						
轴承结构	Bearing structure		交叉滚子轴承 Cross roller bearing						
减速比	Reduction ratio	I	10	18	30	40	50	70	100
额定输出扭矩	Rated output torque	N.m	135	87	135	135	135	135	135
最大输出扭矩	Output torque	N.m	3倍额定扭矩 3 Times rated torque						
定位精度	Positioning accuracy	arc-min	$\leq 1$			$\leq 3$			
反复定位精度	Repeated positioning accuracy	arc-sec	$\leq 15$			$\leq 30$			
容许盘面转速	Allowable disk speed	rpm	200 (间歇运转) Intermittent operation						
适配伺服马达	Adapt to servo motor	W	750-1500						
适配步进马达	Suitable for stepping motor		86-110 步进 Stepper						
容许轴向负载	Allowable axial load	N	4000						
容许惯性力矩	Allowable moment of inertia	N.m	100						
扭转刚性	Torsional rigidity	N.m/arcmin	32						
齿隙	Backlash		无齿隙 (可调节结构) No backlash (Adjustable structure)						
精度寿命	Accuracy life	h	30000h (间歇运转) Intermittent operation						
防护等级	Protection level	IP	50						
润滑方式	Lubrication method		长效润滑 Long-term lubrication						
安装方式	Installation method		任意 Arbitrary						
旋转平台同心度	Concentricity of rotating platform	mm	$\leq 0.01$						
旋转平台平行度	Parallelism of rotating platform	mm	$\leq 0.02$						
传动效率	Transmission efficiency	%	95			90			
噪音	Noise	db	$\leq 63$			$\leq 63$			
重量	Weight	kg	8.1			11.6			
设计承重	Design load	kg	50-70			70			

注 ①HRT200JS系列速比有30/40/50/70/100等。额定输出扭矩110N.m。 ②旋转平台平行度有更高要求请联系我司销售人员  
①HRT200JS series speed ratio has 30/40/50/70/100 etc. The rated output torque is 110N.m. ②If the parallelism of the rotating platform has higher requirements, please contact our sales staff

外形尺寸图表  
Outline dimensional

HRT200-10 配750W伺服接口 for 750W Servo Interface

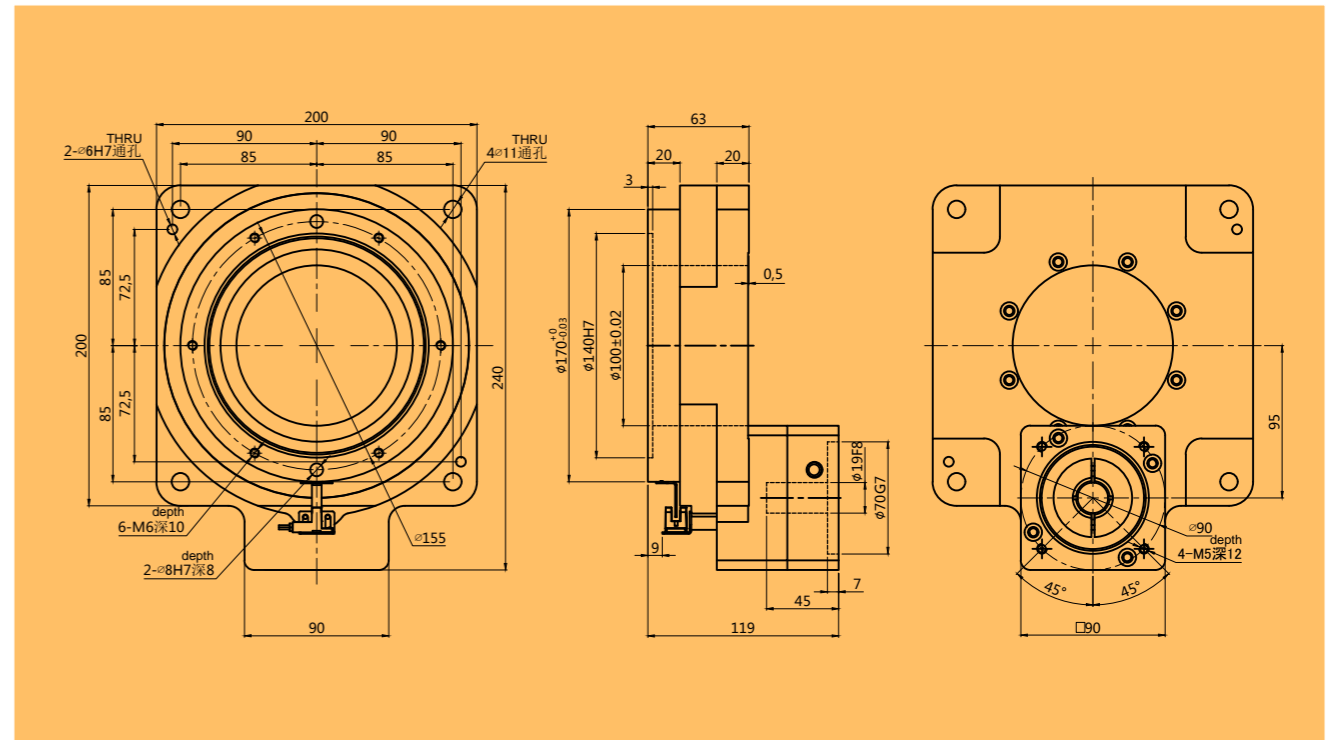

HRT200-10 配86步进接口 for 86 Stepper Interface

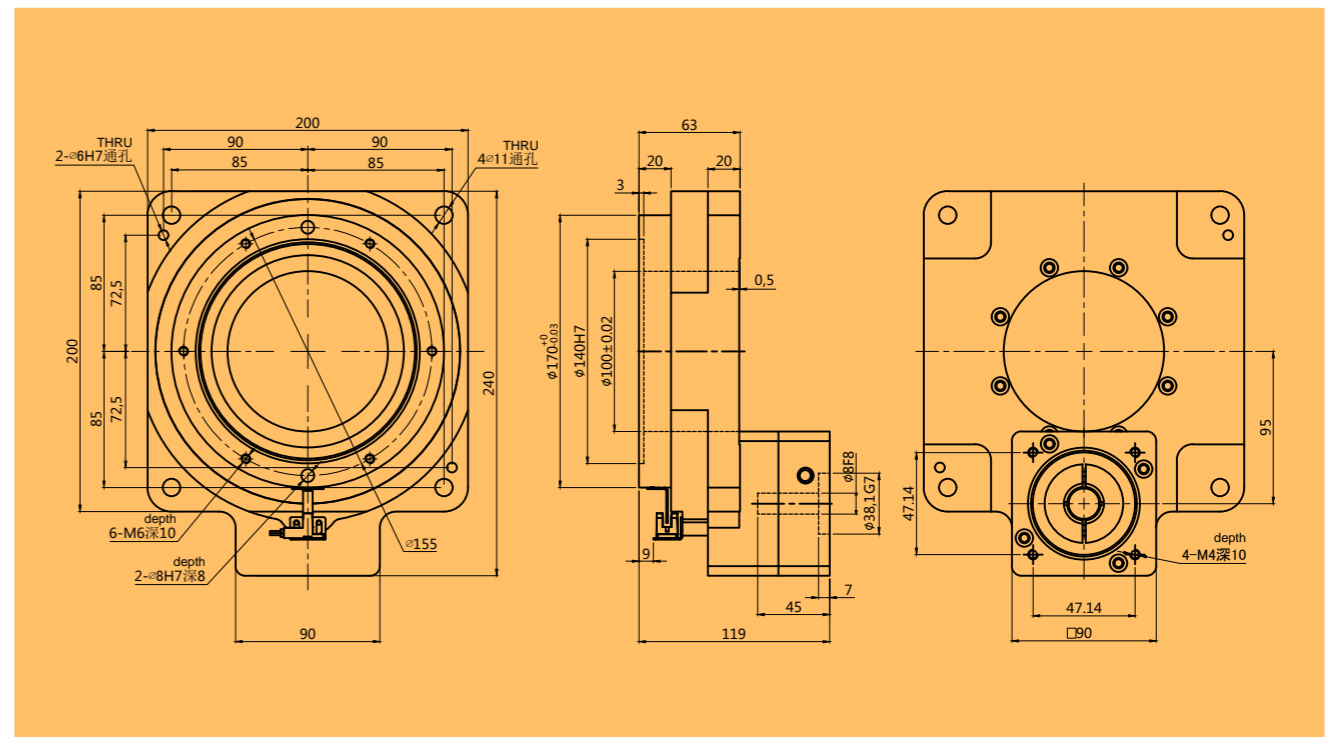

\* 以上技术参数仅供参考，实际根据客户提供的数据，会出具相关的技术参数及尺寸。  
The above data is for reference only. Based on the data provided by the customer, relevant technical parameters and dimensions will be provided



订货型号表示

Ordering Representation

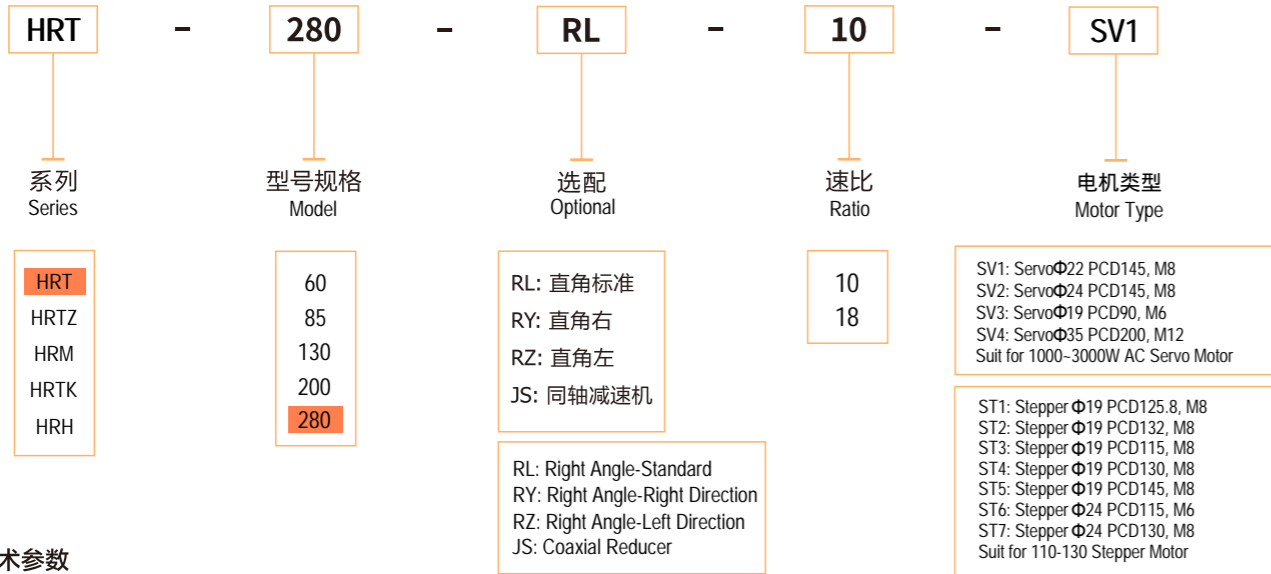

技术参数

Technical Parameter

型号 Model		HRT280	HRT280RL/RY/RZ(JS)					
轴承结构 Bearing structure		交叉滚子轴承 Cross roller bearing						
减速比 Reduction ratio	I	10	18	30	40	50	70	100
额定输出扭矩 Rated output torque	N.m	270	180	270	270	270	270	270
最大输出扭矩 Output torque	N.m	3倍额定扭矩 3 Times rated torque						
定位精度 Positioning accuracy	arc-min	≤1			≤3			
反复定位精度 Repeated positioning accuracy	arc-sec	≤15			≤30			
容许盘面转速 Allowable disk speed	rpm	150 (间歇运转) Intermittent operation						
适配伺服马达 Adapt to servo motor	W	1000-3000						
适配步进马达 Suitable for stepping motor		110-130 步进 Stepper						
容许轴向负载 Allowable axial load	N	8000						
容许惯性力矩 Allowable moment of inertia	N.m	200						
扭转刚性 Torsional rigidity	N.m/arcmin	58						
齿隙 Backlash		无齿隙 (可调节结构) No backlash (Adjustable structure)						
精度寿命 Accuracy life	h	30000h (间歇运转) Intermittent operation						
防护等级 Protection level	IP	50						
润滑方式 Lubrication method		长效润滑 Long-term lubrication						
安装方式 Installation method		任意 Arbitrary						
旋转平台同心度 Concentricity of rotating platform	mm	≤0.015						
旋转平台平行度 Parallelism of rotating platform	mm	≤0.03						
传动效率 Transmission efficiency	%	95			90			
噪音 Noise	db	≤ 67			≤ 67			
重量 Weight	kg	20.3			28			
设计承重 Design load	kg	150			150			

注 旋转平台平行度有更高要求请联系我司销售人员  
If the parallelism of the rotating platform has higher requirements, please contact our sales staff

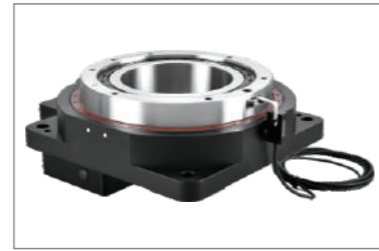

外形尺寸图表

Outline dimensional

HRT280-10 配1KW伺服接口 for 1KW Servo Interface

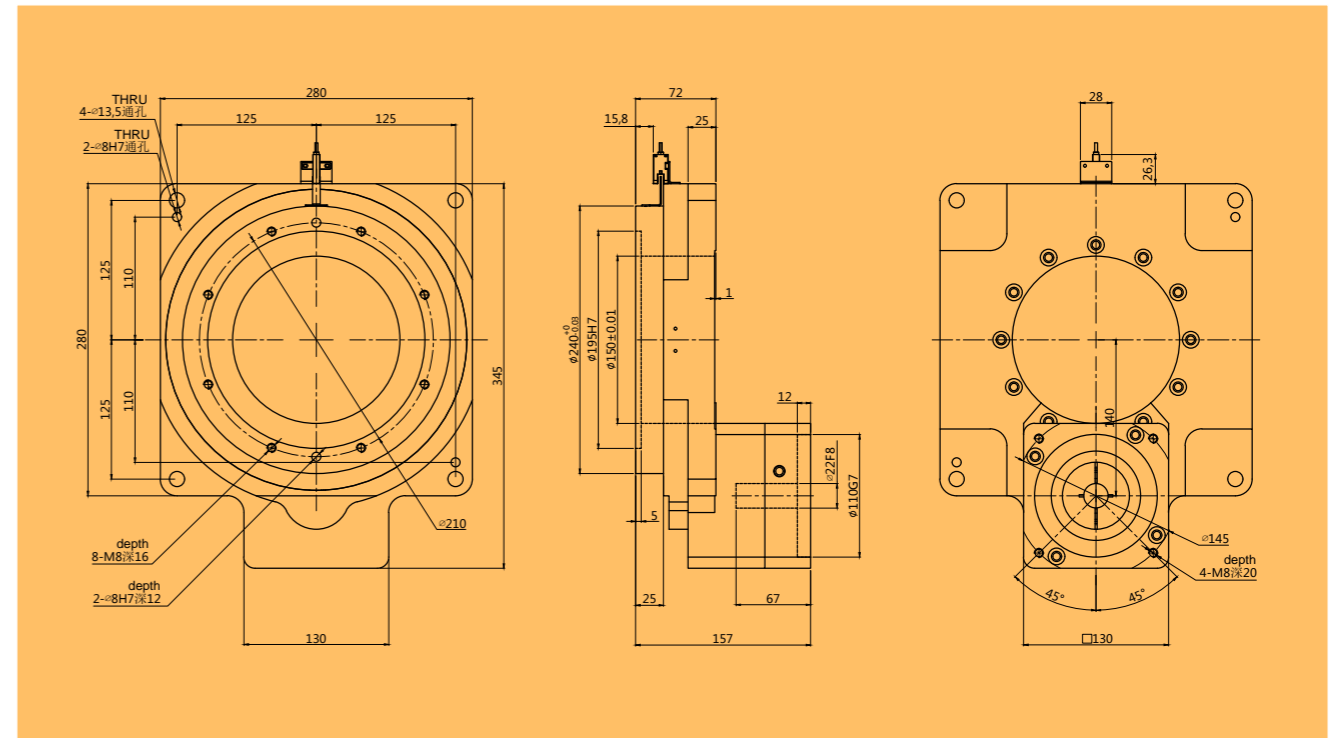

HRT280-10 配110步进接口 for 110 Stepper Interface

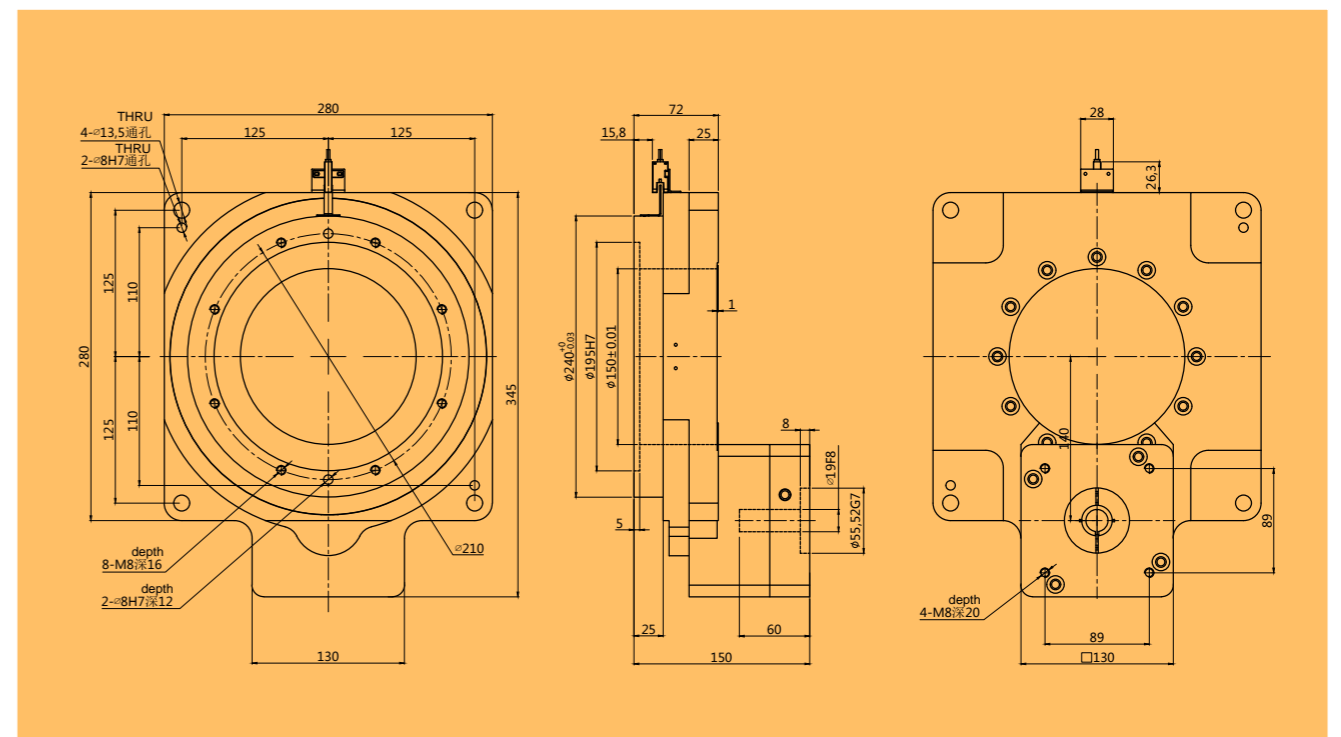

\* 以上技术参数仅供参考，实际根据客户提供的数据，会出具相关的技术参数及尺寸。  
The above data is for reference only. Based on the data provided by the customer, relevant technical parameters and dimensions will be provided